

INTRODUCTION

The Solar Radiation Sensor, or solar pyranometer, measures global radiation, the sum at the point of measurement of both the direct and diffuse components of solar irradiance. The sensor's transducer, which converts incident radiation to electrical current, is a silicon photodiode with wide spectral response. From the sensor's output voltage, the console calculates and displays solar irradiance. It also integrates the irradiance values and displays total incident energy over a set period of time.

The outer shell shields the sensor body from thermal radiation and provides an airflow path for convection cooling of the body, minimizing heating of the sensor interior. It includes a cutoff ring for cosine response, a level indicator, and fins to aid in aligning the sensor with the sun's rays. The space between the shield and the body also provides a runoff path for water, greatly reducing the possibility of rain- or irrigation-water entrapment. The diffuser is welded to the body for a weather-tight seal; it provides an excellent cosine response. The transducer is an hermetically-sealed silicon photodiode with integrated amplifier. Spring-loaded mounting screws, in conjunction with the level indicator, enable rapid and accurate leveling of the sensor. Each sensor is calibrated against a secondary standard Pyranometer in natural daylight.

Specifications

- Operating Temperature : -40° to +65° C
- Storage Temperature : -45° to +70°C
- Transducer : Silicon photodiode
- Spectral Response : 400 to 1100 nanometers Cosine Response
- Percent of Reading : $\pm 3\%$ (0° to $\pm 70^\circ$), $\pm 10\%$ ($\pm 70^\circ$ to $\pm 85^\circ$)
- Percent of Full Scale : $\pm 2\%$ (0° to $\pm 90^\circ$)
- Temperature Coefficient : + 0.12% per °C
- Reference temperature : 25°C
- Housing Material : UV-resistant PVC plastic
- Weight : 250 g
- Range : 0 to 1800 W/m²
- Accuracy : $\pm 3\%$ of full scale
- Drift : up to $\pm 2\%$ per year
- Output : 4-20mA (0- 1800 w/m²), RS485 Modbus (for MST-IRD-04M)
- Power supply : 7- 24 VDC 1mA (typical)

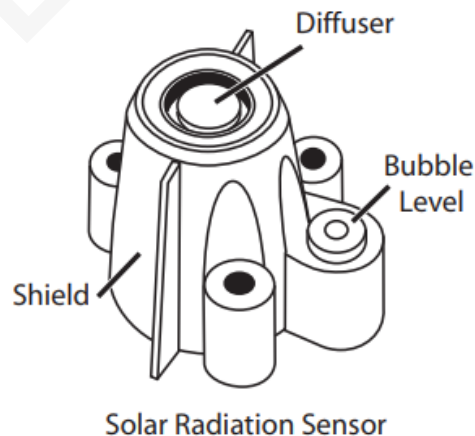

WIRING DIAGRAM

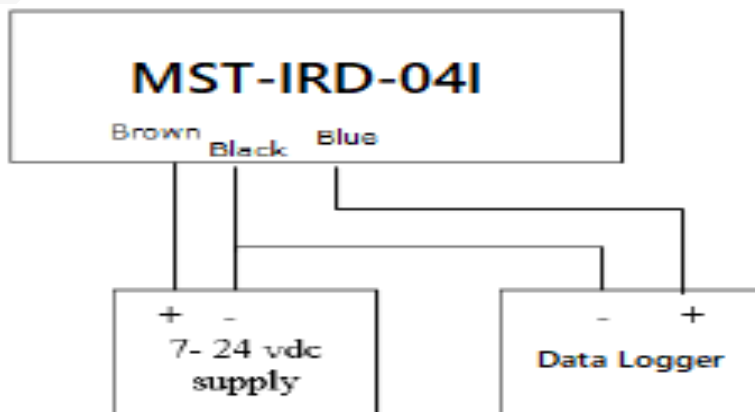

INSTALLATION

- Sensor is to be mounted in an easy-to-reach location in order to clean the dome regularly and carry out maintenance. At the same time, make sure that no buildings, constructions, trees or obstructions exceed the horizontal plane where the irradiation sensor lies. If this is not possible, select a site where obstructions in the path of the sun from sunrise to sunset do not exceed 5 degrees of elevation. N.B The presence of obstructions on the horizon line affects significantly the measurement of direct irradiance
- Sensor is to be located far from any kind of obstruction, which might reflect sunlight (or sun shadow) onto the sensor itself.
- The sunlight sensor must be installed at the same azimuth and tilt angle than the PV array.

TOOLS AND MATERIALS NEEDED

Read this manual before beginning the installation to be sure you have everything you need.

- Wrench or pliers
- Wire cutters and stripper
- Multimeter
- Drill with 3/16 in drill bit (4.7 mm) to drill pilot holes
- Adjustable wrench or 11/32 in. wrench and 7/16 in
- Electrical Tapes to cover the wire

LOCATION RECOMENDATION

Use the following guidelines to determine the best location for mounting the Solar Radiation Sensor

- The sunlight sensor must be installed at the same azimuth and tilt angle than the PV array. (Drill it on the top of the panel)
- Pyranometer is to be located far from any kind of obstruction, which might reflect sunlight (or sun shadow) onto the pyranometer itself.

MOUNTING

- Using the bubble level on the sensor as a guide, adjust the sensor until it is level by tightening or loosening the screws. The top of the Solar Radiation sensor should be even with or slightly above the rim of the rain cone. The entire comb structure of the UV Radiation sensor should be above the rim of the rain cone
- Final leveling of the sensor(s) should be done with the ISS mounted in its operating location
- Ensure that the cables are free of crimps. Secure them to the support tubes with the provided cable ties so that they will not fray in the wind.
- Shade the sensor and make sure the reading changes

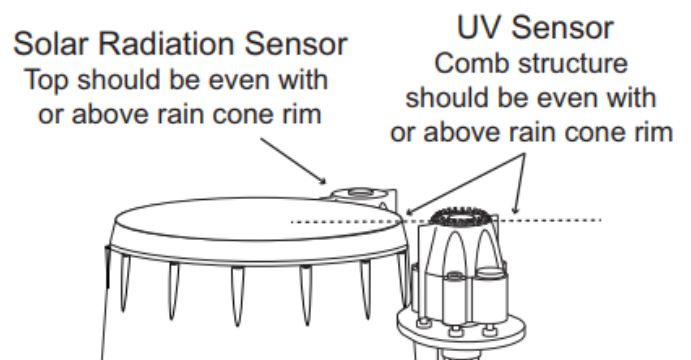
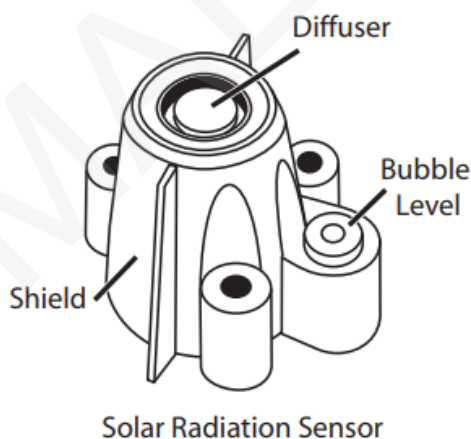

- If necessary, adjust the position of the sensor by tightening or loosening the levelling screws. When pointed directly at the sun, the shadows from the alignment fins should appear as shown in the illustration below

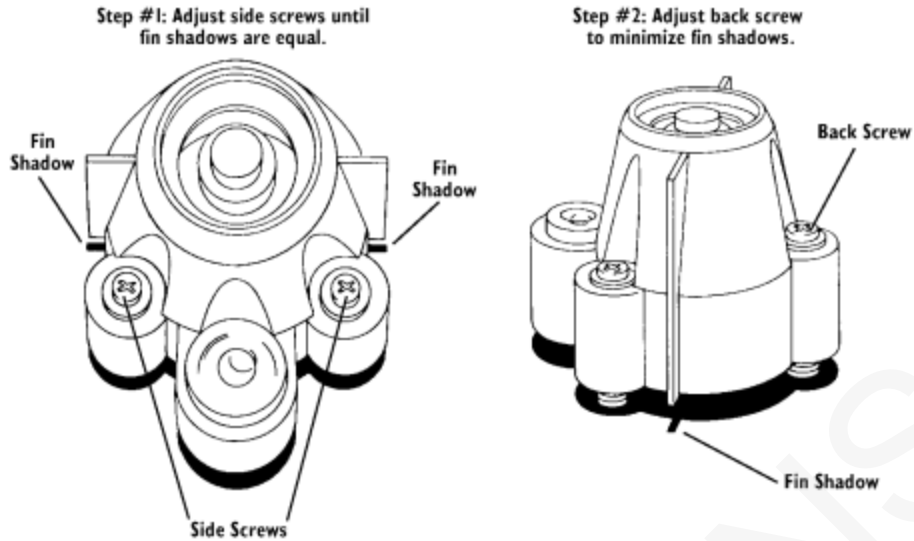

Example Installations :



CALIBRATION

- If using Modbus sensor then the Pyranometer is factory calibrated.
- If using analog output sensor then use the following info to calibrate.
Output - 0 to 5 VDC (0- 1800 w/m²)
Irradiance in W/m²=360*Output voltage (in Volt) measured by the voltmeter

It is highly recommended that the calibration be checked annually

SENSOR MAINTENANCE

- The effectiveness of the radiation shield will be reduced if the surfaces of the shield are dirty. Wipe the surfaces of the shield with a damp cloth to remove dirt and dust. You can wash it using water and standard papers for lens, and if necessary using pure ETHYL alcohol. After using alcohol, clean again the dome with water only.
- Due to the sensitivity of ultraviolet and solar radiation sensors, it is common practice for manufacturers to recommend recalibration after a period of time. You can get approximately 3% drift per year on the readings from these sensors. For applications demanding higher accuracy, the sensors should be calibrated once every year